

A-max 22 Ø22 mm, Precious Metal Brushes CLL, 5 Watt, CE approved

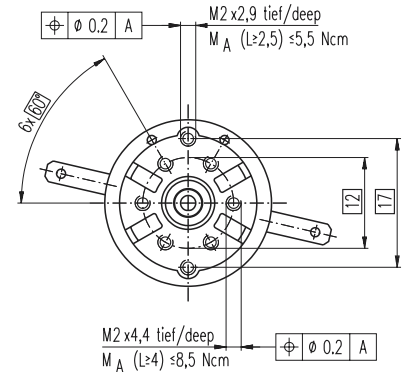
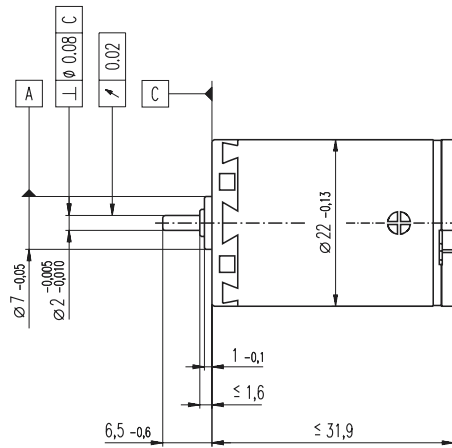
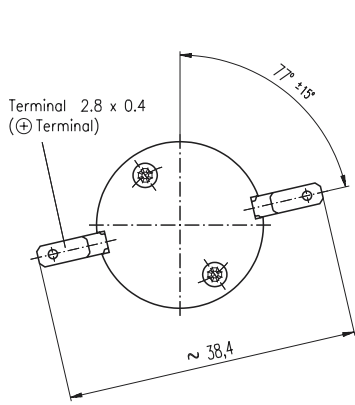

- █ Stock program
- Standard program
- Special program (on request!)

Order Number

Motor Data		Order Number												
		110117	110119	110120	110121	110122	110123	110124	110125	110126	110127	110128	110129	
1	Assigned power rating	W	5.0	5.0	5.0	5.0	5.0	5.0	5.0	5.0	5.0	5.0	5.0	5.0
2	Nominal voltage	Volt	6.0	9.0	9.0	12.0	12.0	15.0	18.0	24.0	30.0	36.0	48.0	48.0
3	No load speed	rpm	9630	9970	8760	10400	9400	10300	9970	10700	10800	9800	9280	8370
4	Stall torque	mNm	20.7	23.2	20.7	24.6	21.6	23.6	22.6	24.2	24.2	21.5	19.5	17.9
5	Speed / torque gradient	rpm / mNm	469	433	426	428	438	438	444	445	451	460	480	472
6	No load current	mA	30	21	17	17	14	13	10	9	7	5	3	3
7	Starting current	mA	3510	2710	2130	2250	1790	1700	1320	1140	921	617	399	330
8	Terminal resistance	Ohm	1.71	3.32	4.22	5.33	6.71	8.82	13.6	21.0	32.6	58.4	120	145
9	Max. permissible speed	rpm	10600	10600	10600	10600	10600	10600	10600	10600	10600	10600	10600	10600
10	Max. continuous current	mA	840	751	666	593	528	461	371	298	240	179	125	113
11	Max. continuous torque	mNm	4.96	6.43	6.48	6.47	6.39	6.39	6.34	6.33	6.29	6.23	6.10	6.15
12	Max. power output at nominal voltage	mW	5210	6030	4740	6680	5310	6320	5890	6780	6840	5490	4730	3910
13	Max. efficiency	%	83	84	83	84	83	84	83	84	84	83	83	82
14	Torque constant	mNm / A	5.90	8.55	9.73	10.9	12.1	13.9	17.1	21.2	26.3	34.8	49.0	54.3
15	Speed constant	rpm / V	1620	1120	981	875	790	689	558	450	364	274	195	176
16	Mechanical time constant	ms	19	19	19	19	19	18	18	18	18	18	19	19
17	Rotor inertia	gcm ²	3.88	4.10	4.16	4.13	4.04	4.03	3.97	3.96	3.91	3.84	3.70	3.75
18	Terminal inductance	mH	0.11	0.22	0.29	0.36	0.45	0.59	0.89	1.37	2.10	3.69	7.30	8.98
19	Thermal resistance housing-ambient	K / W	20	20	20	20	20	20	20	20	20	20	20	20
20	Thermal resistance rotor-housing	K / W	6.0	6.0	6.0	6.0	6.0	6.0	6.0	6.0	6.0	6.0	6.0	6.0
21	Thermal time constant winding	s	9	10	10	10	9	9	9	9	9	9	8	9

Specifications

- Axial play 0.05 - 0.15 mm
- Max. **sleeve bearing** loads
 - axial (dynamic) 1.0 N
 - radial (5 mm from flange) 2.8 N
 - Press-fit force (static) 80 N
- Max. **ball bearing** loads
 - axial (dynamic) 3.3 N
 - radial (5 mm from flange) 12.3 N
 - Press-fit force (static) 45 N
- Radial play **sleeve bearing** 0.012 mm
- Radial play **ball bearing** 0.025 mm
- Ambient temperature range -30 / +85°C
- Max. rotor temperature +85°C
- Number of commutator segments 9
- Weight of motor 54 g
- Values listed in the table are nominal. For applicable tolerances (see page 43). For additional details please use the maxon selection program on the enclosed CD-Rom.
- CLL = Capacitor Long Life

Operating Range

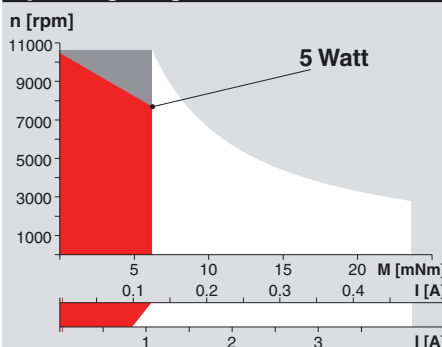

Comments

- █ **Recommended operating range**
- Continuous operation**
In observation of above listed thermal resistances (lines 19 and 20) the maximum permissible rotor temperature will be reached during continuous operation at 25°C ambient. = Thermal limit.
- Short term operation**
The motor may be briefly overloaded (recurring).
- █ **110128** Motor with high resistance winding
- █ **110117** Motor with low resistance winding

Details on page 49

maxon Modular System

- Planetary Gearhead** Ø22 mm
0.1 - 0.6 Nm
Details page 175 / 176
- Planetary Gearhead** Ø22 mm
0.5 - 1.0 Nm
Details page 177
- Planetary Gearhead** Ø22 mm
0.5 - 2.0 Nm
Details page 178
- Spur Gearhead** Ø24 mm
0.1 Nm
Details page 179

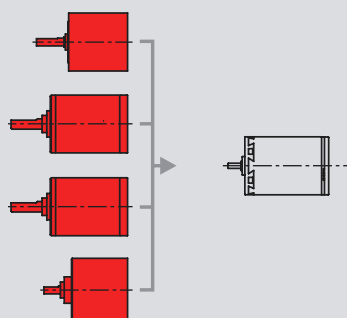

- Digital Magnetic Encoder** Ø13 mm
16 CPT, 2 channels
Details page 212
- Digital MR Encoder**
32 CPT, 2 / 3 channels
Details page 199
- Digital MR Encoder**
128 / 256 / 512 CPT,
2 / 3 channels
Details page 200