

SANYO DENKI 103H546 - 0440 Stepper Motor

MODEL □	Step Angle Deg/Step	Voltage V	Current A/Phase	Resistance Ω /Phase	Inductance mH/Phase	Holding Torque kg · cm	Rotor Inertia g · cm ²	Weight kg
103H546-0440	1.8	3.15	1	3.15	2.8	1.5	30	0.2

★ Replace this with a common connector.

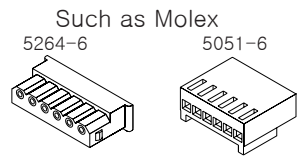

Housing : EHR-6(JST)
Connector: SEH-001T-P0.6(JST)

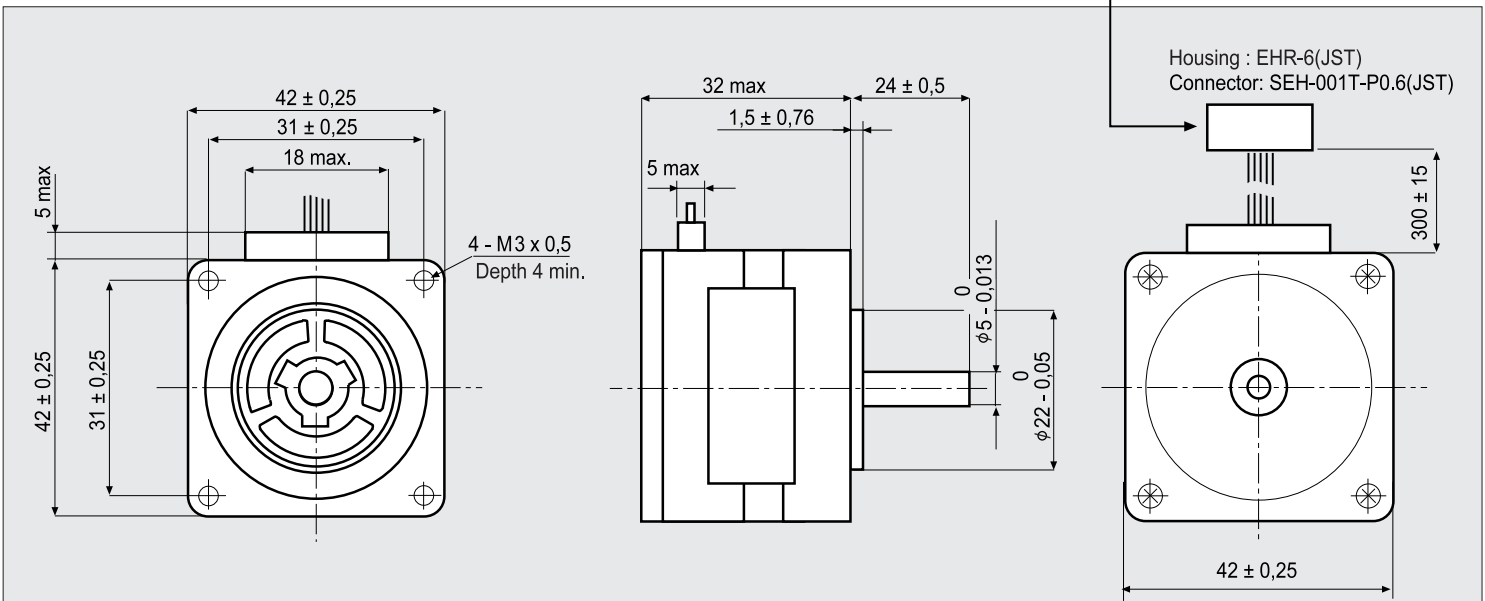

Two phase full step driving example

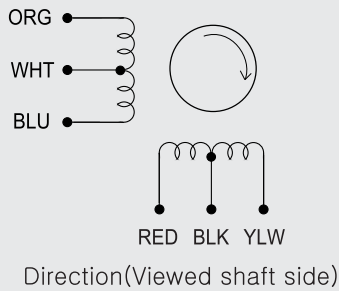

		Lead Wire Color				
		WHT BLK	ORG	RED	BLU	YLW
STEP	1	+	-	-		
	2	+		-	-	
	3	+			-	-
	4	+	-			-