

# MD03 - 50Volt 20Amp H Bridge Motor Drive

## Overview

The MD03 is a medium power motor driver, designed to supply power beyond that of any of the low power single chip H-Bridges that exist. Main features are ease of use and flexibility. The 15v MOSFET drive voltage is generated onboard with a charge pump, so the module requires only two supply voltages;

1. A standard 5V supply for the control logic, only 50mA maximum is required.
2. Motor voltage, anything from 5vdc to 50vdc to suit your motors

Control of the module can be any of;

- a. I2C bus, up to 8 MD03 modules, switch selectable addresses.
- b. 0v-2.5-5v analog input. 0v full reverse, 2.5v center stop, 5v full forward.
- c. 0v-5v analog input with separate direction control
- d. RC mode. Controlled directly from the RC receiver output.
- e. PWM. A simple onboard filter means you can use a 0%-100% 20khz or greater instead of analog.

## Motor connections

**Note - There is no fuse on the PCB. You should provide a 25/30A fuse in line with the +v battery terminal.**

**Don't Ignore this, High currents can be dangerous!**

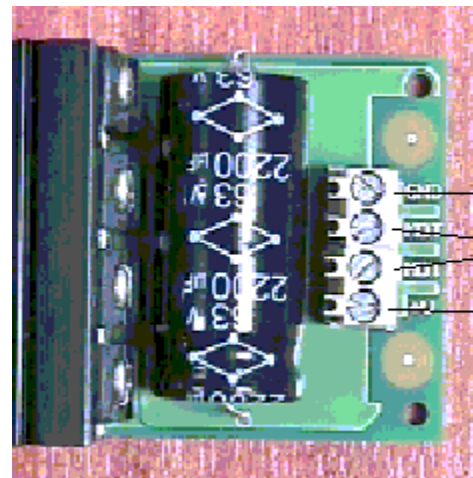

0v or Ground on the Motor Battery

To the Motor Terminals, Swap these if motor runs in wrong direction

25A FUSE — +V on the Motor Battery

**Be sure to use cable rated for at least 25/30A for the Battery, Fuse and Motor leads.**

## Control Connections

### **Analog Mode - 0v-2.5v-5v**

In this mode the motor is controlled by a 0v to 5v analog signal only on the SDA line. Pin SCL is unused and should be connected to either +5v or 0v.

0v is maximum reverse power

2.5v is the center stop position

5v is full forward power

There is a small (2.7%) dead band around 2.5v to provide a stable off position. Input impedance is 47k.

### **Analog Mode - 0v-5v**

In this mode the motor is controlled by a 0v to 5v analog signal on the SDA line and direction on SCL.

0v is stop position

5v is full power

Pin SCL is the logic level (ttl) direction control. logic 0 for reverse direction and logic 1 for forward direction.

You may also use a PWM signal instead of an analog voltage on the SDA line. There is a simple resistor/capacitor filter on the module which will generate the analog voltage from the incoming PWM signal. your PWM signal should be 20khz or greater in frequency and ideally, come from a CMOS gate (0-5v) rather than ttl (0-3.5v ish). a 0% duty cycle will represent 0v and a 100% duty cycle representing 5v. This applies to both the above analog modes.

### **RC Mode**

This mode allows direct connection to standard model radio control receivers. Most receivers work from a 4.8v-6v battery pack and can be powered by 5v supply that powers the MD03 logic. The control pulse (Yellow) from the receiver should be connected to the SDA terminal. The SCL terminal is unused and should be connected to either +5v or 0v. Connect the receiver supply (Red) to +5v logic supply and the receiver 0v ground (Black) to the MD03 logic ground. The output from an RC receiver is a high pulse 1.5mS wide when the joystick is central. This varies down to 1.1mS and up to 1.9mS as the joystick is moved. This range can be shifted by the centering control by +/-100uS from 1mS-1.8mS to 1.2mS-2mS. The MD03 provides full control in the range 1.1mS to 1.9mS with 1.5mS being the center off position. There is a 7uS dead zone centered on 1.5mS for the off position. The Radio Transmitter centering control should be adjusted so that the motor is off when the joystick is released.

### **I2C Mode**

I2C mode allows the MD03 to be connected to popular controllers such as the [OOPic](#) and BS2p, and a wide range of micro-controllers like [PIC's](#), 8051's and H8's.

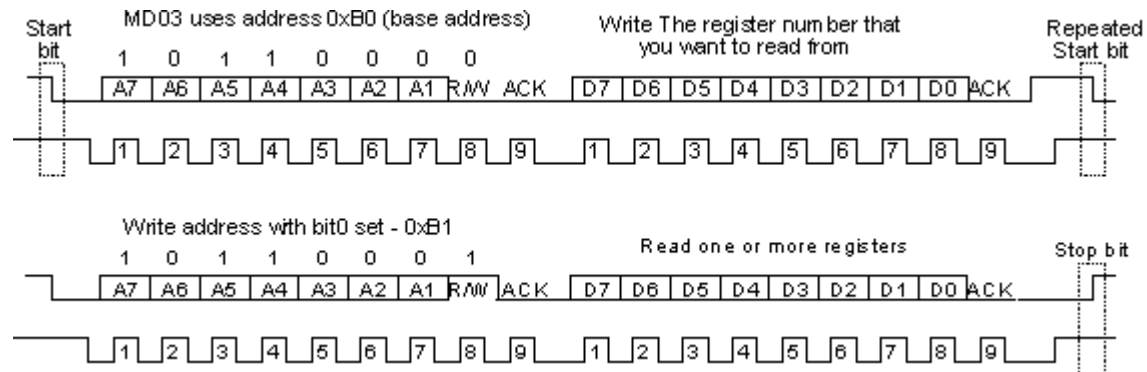

I2C communication protocol with the MD03 module is the same as popular eeprom's such as the 24C04. To read one or more of the MD03 registers, first send a start bit, the module address (0XB0 is the base address) with the read/write bit low, then the register number you wish to read. This is followed by a repeated start and the module address again with the read/write bit high (0XB1). You now read one more registers. The MD03 has 8 registers numbered 0 to 7 as follows;

Register Address	Name	Read/Write	Description
0	Command	R/W	Write 01 Forwards - 02 Reverse - 00 to Stop
1	Status	Read only	Acceleration, Temperature and Current Status
2	Speed	R/W	Motor Speed 0-255 (0x00 - 0xFF)
3	Acceleration	R/W	Motor Acceleration 0-255 (0x00 - 0xFF)
4	Temperature	Read only	Module temperature
5	Motor Current	Read only	Motor Current
6	Unused	Read only	Read as zero
7	Software Revision	Read only	Software Revision Number

#### Command Register

Controls the motor start, stop and direction. Write 1 to drive forwards, Write 2 to reverse an 0 to stop. Be sure to have set the speed and acceleration before issuing these commands.

#### Status Register

Shows the status of the MD03

Bit 7 (msb)	6	5	4	3	2	1	Bit 0 (lsb)
Busy	-	-	-	-	over-temperature limiter	over-current limiter	Acceleration in progress

Bit 0 is read as high when the drive is still accelerating the motor to the requested speed. It will be cleared when the requested speed is achieved or the over current or over temperature limiters are active.

Bit 1 set high indicates that the current through the motor has reached 20Amps and is being limited to that value. The Red LED will be illuminated when this happens.

Bit 2 set high indicates that the over temperature limiter is active. Above a preset threshold, the motor current will be reduced in proportion to the MD03 temperature. The module can still be used but the motor power will be limited. The Red LED will be illuminated when this happens. It should be noted that a few minutes of running continuously at 20A will cause the heatsink to get hot - watch your fingers!

Bit 7 is the busy flag. It is set high when you issue a new command to the module. It is cleared very quickly and you are unlikely ever to see it set.

#### Speed Register

Sets the maximum speed that the motor will accelerate to. It is actually the 8-bit value sent to the modules PWM controller. Write a value of 0 to 243 (numbers from 243 to 255 are clamped to 243) . The larger the number, the more power is applied to the motor.

#### Acceleration Register

This sets the rate at which the motor accelerates or decelerates from where it is towards the new speed set by the speed register. Write a value of 0 to 255, the larger the number the longer the module will take to reach the new speed. Writing zero to the acceleration register will allow maximum acceleration of 0 to full in 0.187 seconds. This value actually controls a timer which steps the current motor speed towards the requested motor speed. It does this every  $((\text{acceleration register}) * 125) + 768$  uS. A value of zero gives 768uS/step or  $243 * 768 = 186624$  uS (0.187s) to accelerate from 0 to full. A value of 255 is  $((255 * 125) + 768) * 243 = 7932249$  uS or just under 8 seconds.

#### Temperature Register

This is the value used internally to limit the motor current if the module gets too hot. You do not need to read or do anything with it. It does not read degrees, in fact the number goes down as the temperature goes up! It is actually reading the forward voltage drop of a diode located under the 0.003R current sense resistor. The number drops by 1 count approx. every 1.42 degrees C.

#### Motor Current

This is the value used internally to limit the motor current to 20A. You do not need to read or do anything with it. The value is proportional to motor current, with a value of 186 representing the 20A limit.

#### Software Revision number

The revision number of the software in the modules PIC16F872 controller - currently 03 at the time of writing.

## Mode Switches

The 4 mode switches set the operating mode of the MD03. They are read once only when the module is powered up. You cannot switch modes while the unit is on.

Mode	Switch 1	Switch 2	Switch 3	Switch 4
I2C Bus - address 0xB0	On	On	On	On
I2C Bus - address 0xB2	Off	On	On	On
I2C Bus - address 0xB4	On	Off	On	On
I2C Bus - address 0xB6	Off	Off	On	On
I2C Bus - address 0xB8	On	On	Off	On
I2C Bus - address 0xBA	Off	On	Off	On
I2C Bus - address 0xBC	On	Off	Off	On
I2C Bus - address 0xBE	Off	Off	Off	On
0v - 2.5v - 5v Analog	On	On	On	Off
0v - 5v Analog + Direction	Off	On	On	Off
Radio Control	On	Off	On	Off

All other combinations are invalid, the LED will blink and nothing else will happen.

Note that I2C addresses are the upper 7 bits. Bit 0 the the read/write bit, so addresses 0xB0/0xB1 are write/read respectively to the same address.