

1999年 9月17日 17時14分

オプトデバイス事業部 企画部

NO. 5431 P. 1

PREPARED BY: <i>J. Tabatake Aug 21, 1999</i>	DATE: <i>Aug 21, 1999</i>	<h1>SHARP</h1>	SPEC. No. ED-99170
APPROVED BY: <i>T. Mizoguchi Aug 31, 1999</i>	DATE: <i>Aug 31, 1999</i>		ELECTRONIC COMPONENTS GROUP SHARP CORPORATION <b>SPECIFICATION</b>

REFERENCE

DEVICE SPECIFICATION FOR

**DISTANCE MEASURING SENSOR**

MODEL No.

**GP2D120**

1. These specification sheets include materials protected under copyright of Sharp Corporation ("Sharp"). Please do not reproduce or cause anyone to reproduce them without Sharp's consent.
2. When using this product, please observe the absolute maximum ratings and the instructions for use outlined in these specification sheets, as well as the precautions mentioned below. Sharp assumes no responsibility for any damage resulting from use of the product which does not comply with the absolute maximum ratings and the instructions included in these specification sheets, and the precautions mentioned below.
 

(Precautions)

  - (1) This product is designed for use in the following application areas ;
 

• OA equipment • Audio visual equipment • Home appliances  
 • Telecommunication equipment (Terminal) • Measuring equipment

If the use of the product in the above application areas is for equipment listed in paragraphs (2) or (3), please be sure to observe the precautions given in those respective paragraphs.
  - (2) Appropriate measures, such as fail-safe design and redundant design considering the safety design of the overall system and equipment, should be taken to ensure reliability and safety when this product is used for equipment which demands high reliability and safety in function and precision, such as ;
 

• Transportation control and safety equipment (aircraft, train, automobile etc.)  
 • Traffic signals • Gas leakage sensor breakers • Rescue and security equipment  
 • Other safety equipment
  - (3) Please do not use this product for equipment which require extremely high reliability and safety in function and precision, such as ;
 

• Space equipment • Telecommunication equipment (for trunk lines)  
 • Nuclear power control equipment • Medical equipment
  - (4) Please contact and consult with a Sharp sales representative if there are any questions regarding interpretation of the above three paragraphs.
3. Please contact and consult with a Sharp sales representative for any questions about this product.

CUSTOMER'S APPROVAL

DATE \_\_\_\_\_

BY \_\_\_\_\_

DATE PRESENTED BY

*for* *K. Ozawa*

K. Ozawa,  
 Department General Manager of  
 Engineering Dept., V  
 Opto-Electronic Devices Div.  
 ELECOM Group  
 SHARP CORPORATION

1999年 9月17日 17時15分

オプトデバイス事業部 企画部

NO. 5431 P. 2

**SHARP CORPORATION**

ED-99170	August 30, 1999
MODEL No.	PAGE
GP2D120	1/9

**REFERENCE****1. Application**

This specification applies to the outline and characteristics for analog output type distance measuring sensor, Model No. GP2D120.

**2. Outline**

Refer to the attached drawing No. SOD03596.

**3. Ratings and characteristics**

3-1 Constitution diagram : Refer to the attached sheet, page 4.

3-2 Absolute maximum ratings : Refer to the attached sheet, page 4.

3-3 Electro-optical Characteristics : Refer to the attached sheet, page 5.

3-4 Timing chart : Refer to the attached sheet, page 5.

**4. Reliability**

Refer to the attached sheet, page 6.

**5. Incoming inspection**

Refer to the attached sheet, page 7.

**6. Supplement****6-1 GP2D120 Example of Output distance characteristics**

Refer to the attached sheet, page 8.

**6-2 GP2D120 Example of output characteristics with inverse number of distance**

Refer to the attached sheet, page 9.

**6-3 ODS materials**

This product shall not contain the following materials.  
Also, the following materials shall not be used in the production process for this product.

Materials for ODS : CFC<sub>s</sub>, Halon, Carbon tetrachloride,  
1,1,1-Trichloroethane (Methylchloroform)

**6-4 Brominated flame retardants**

Specific brominated flame retardants such as the PBBO<sub>s</sub> and PBB<sub>s</sub> are not used in this device at all.

**6-5 Product mass : 3.6g (TYP.)**

1999年 9月17日 17時15分

オプトデバイス事業部 企画部

NO. 5431 P. 3

SHARP CORPORATION

ED-99170

August 30, 1999

MODEL No.

GP2D120

PAGE

2/9

**REFERENCE**

## 7. Notes

- 7-1 Lens of this device shall be kept cleanly. There are cases that dust, water or oil and so on deteriorate the characteristics of this device. Please consider in actual application.
- 7-2 In case that protection cover is set in front of the emitter and detector portion, the protection cover which has the most efficient transmittance at the emitting wavelength range of LED for the GP2D120 ( $\lambda=850\text{nm}\pm 70\text{nm}$ ), shall be recommended to use. The face and back of protection cover should be mirror polishing. Also, as there are cases that the characteristics may not be satisfied with according to the distance between the protection cover and the GP2D120 or the thickness of the protection cover, please use the GP2D120 after confirming the operation sufficiently in actual application.
- 7-3 In case that there is an object near to light exits of the sensor between the sensor and the detected object, please use this device after confirming sufficiently what the characteristics of this sensor do not change by the object.
- 7-4 When the detector surface receive direct light from the sun, Tungsten lamp and so on, there are cases that it can not measure the distance exactly. Please consider the design that the detector does not receive direct light from such light source.
- 7-5 Distance between sensor and mirror reflector can not sometimes measure exactly. In case of changing the mounting angle of the GP2D120, it may measure the distance exactly.
- 7-6 In case that reflective object has boundary line clearly, there is cases that distance can not measure exactly. At that time, if direction of boundary line and the line between emitter center and detector center parallels, it is possible to decrease deviation of measuring distance.

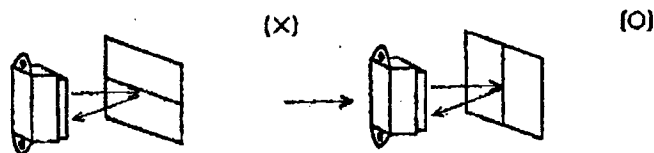

- 7-7 In order to decrease measuring error by moving direction of object, we recommend to mount the sensor like below drawing.

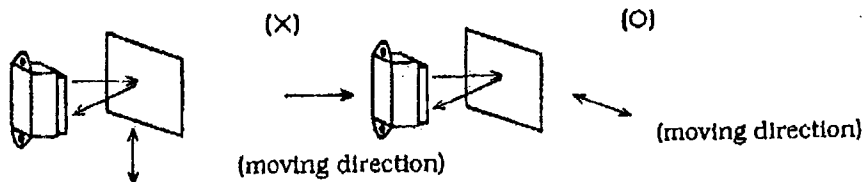

- 7-8 In order to stabilize power supply line, we recommend to connect a by-pass capacitor of  $10\ \mu\text{F}$  or more between Vcc and GND near the GP2D120.
- 7-9 Please don't do washing. Washing may deteriorate the characteristics of optical system and so on.
- 7-10 There are some possibilities that the sensor inside the case package with lens may be exposed to the excessive mechanical stress. Please be careful not to cause any excessive pressure on the case package with lens and also on the PCB at the assembly and inserting of the set.

1999年 9月17日 17時16分

オプトデバイス事業部 企画

NO. 5431 P. 4

**SHARP CORPORATION**

ED-99170	August 30, 1999
MODEL No. GP2D120	PAGE 3/9

REFERENCE

2. Outline (Drawing No. SOD03596)

Scale : 2/1

Unit : mm

Stamp

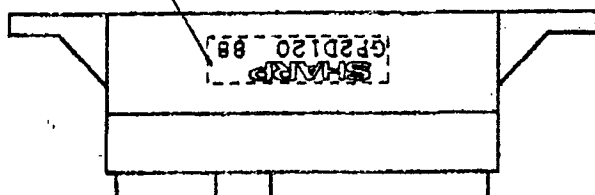

Stamp (Example)

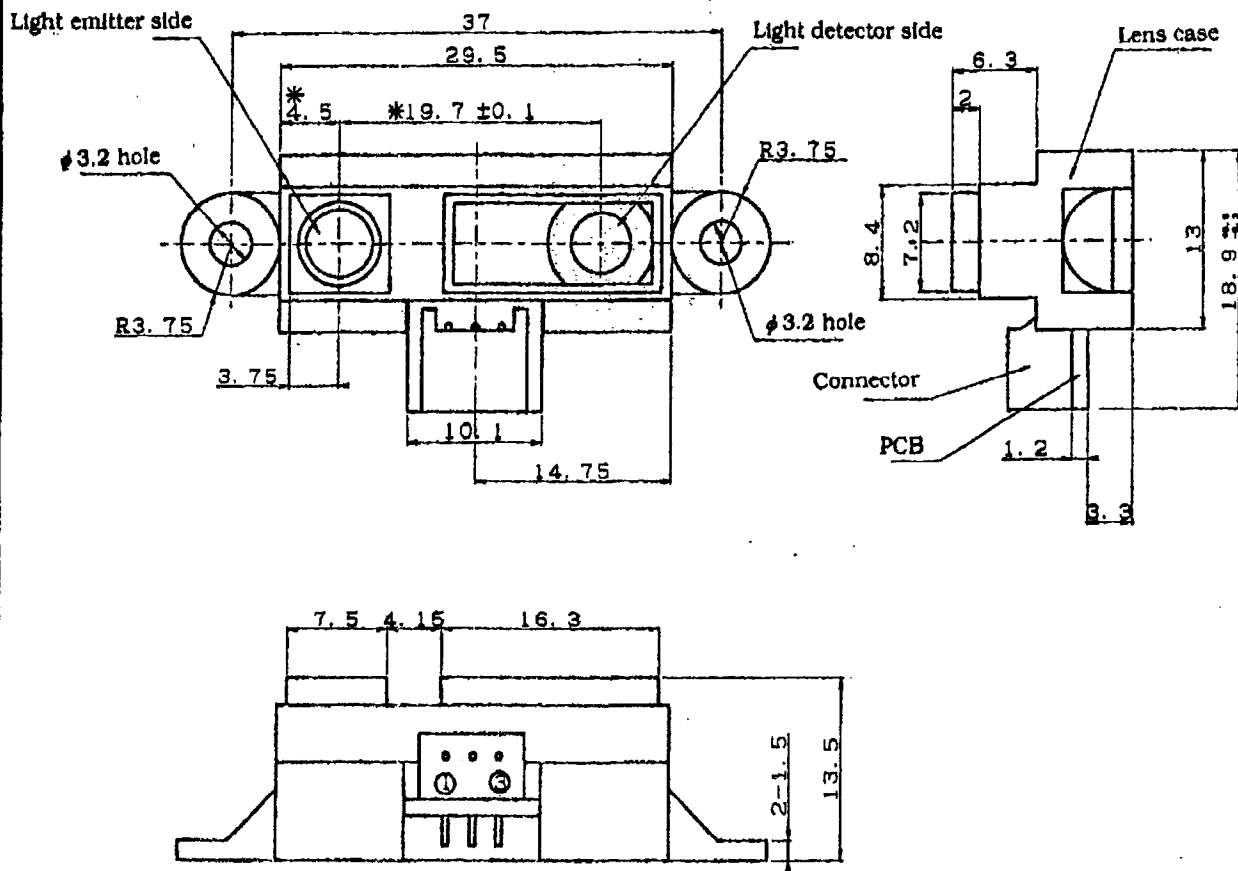
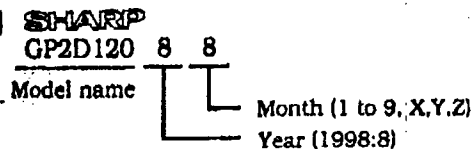

Connector signal

	Signal name
①	V <sub>o</sub>
②	GND
③	V <sub>cc</sub>

Connector : J.S.T. TRADING COMPANY, LTD.  
S3B-PH

Note 1) \* dimension shall be reference lens center.

Note 2) Unspecified tolerance shall be ±0.3mm.

1999年 9月17日 17時16分

オプトデバイス事業部 企画部

NO. 5431 P. 5

SHARP CORPORATION

ED-99170

August 30, 1999

MODEL No.

GP2D120

PAGE

4/9

**REFERENCE**

3. Ratings and characteristics

3-1 Constitution diagram

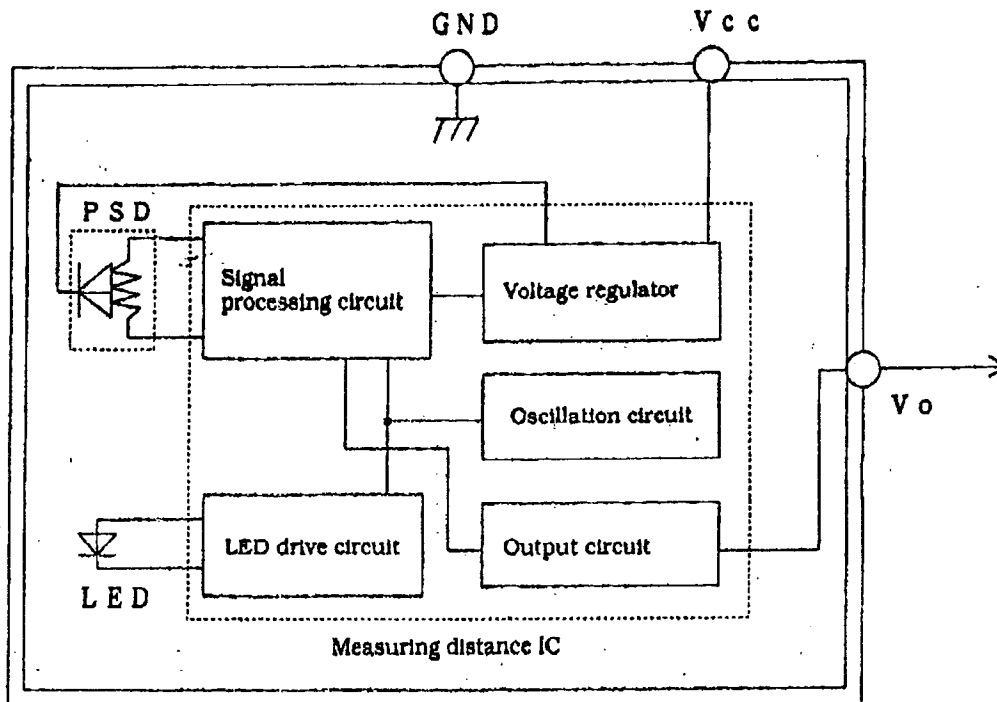

3-2 Absolute maximum ratings

(Ta=25°C, Vcc=5V)

Parameter	Symbol	Rating	Unit	Remark
Supply voltage	Vcc	-0.3 to +7	V	
Output terminal voltage	Vo	-0.3 to Vcc+0.3	V	
Operating temperature	Topr	-10 to +60	°C	
Storage temperature	Tstg	-40 to +70	°C	

• Operating Supply Voltage

Parameter	Symbol	Rating	Unit	Remark
Operating Supply Voltage	Vcc	4.5 to 5.5	V	

1999年 9月17日 17時16分

オプトデバイス事業部 企画部

NO. 5431 P. 6

SHARP CORPORATION

ED-99170	August 30, 1999
MODEL No. GP2D120	PAGE 5/9

**REFERENCE**

## 3-3 Electro-optical Characteristics

(Ta=25°C, Vcc=5V)

Parameter	Symbol	Conditions	Min.	Typ.	Max.	Unit
Measuring distance range	$\Delta L$	(*)	4	-	30	cm
Output terminal voltage	V <sub>o</sub>	L=30cm (*)	0.25	0.4	0.55	V
Output voltage difference	$\Delta V_o$	Output change at L change (30cm → 4cm) (*)	1.95	2.25	2.55	V
Average supply current	I <sub>cc</sub>	L=30cm (*)	-	33	50	mA

\* L: Distance to reflective object

(\*) Using reflective object: White paper (Made by Kodak Co. Ltd. gray cards R-27 · white face, reflective ratio: 90%)

## 3-4 Timing chart

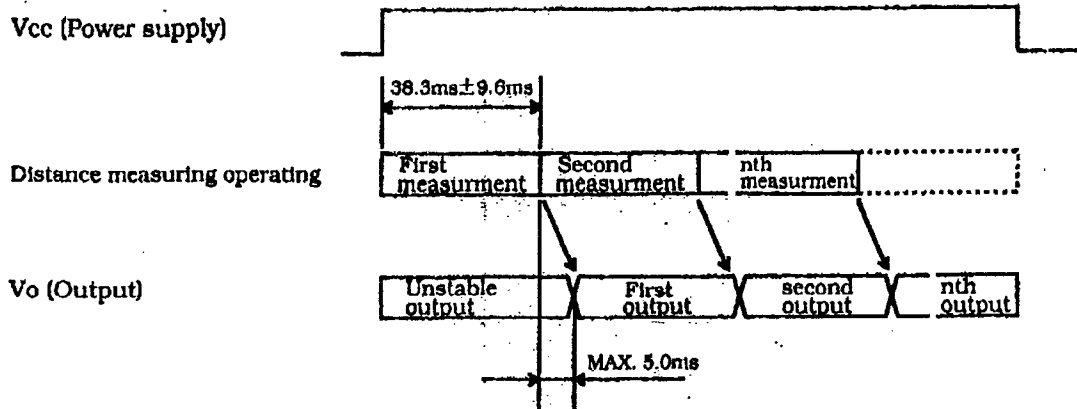

1999年 9月17日 17時16分

オプトデバイス事業部 企画部

NO. 5431 P. 7

**SHARP CORPORATION**

ED-99170

August 30, 1999

MODEL No.

GP2D120

PAGE

6/9

**REFERENCE****4. Reliability**

The reliability of products shall satisfy items listed below.

Confidence level : 90%  
LTPD : 20%/40%

No.	Test Items	Test Conditions	Failure Judgement Criteria	Samples (n) Defective(C)
1	Temperature cycling	1 cycle -40°C ↔ +70°C (30min) (30min) 25 cycles test	Initial $\times 0.8 > V_o$  $V_o > \text{Initial} \times 1.2$  (*1)	n=11, C=0
2	High temp. and high humidity storage	+40°C, 90%RH, 500h		n=11, C=0
3	High temp. storage	+70°C, 500h		n=11, C=0
4	Low temp. storage	-40°C, 500h		n=11, C=0
5	Operation life (High temp.)	+60°C, Vcc=5V, 500h		n=11, C=0
6	Mechanical shock	100m/s <sup>2</sup> , 6.0ms 3times/±X, ±Y, ±Z direction		n=6, C=0
7	Variable frequency vibration	10 to 55 to 10Hz/1min Overall amplitude : 1.5mm 2h/X, Y, Z direction		n=6, C=0

\*1 Test conditions are according to 3-3 Electro-optical characteristics.

\*2 After test, measurement shall be measured after leaving under the normal temperature and the normal humidity for two hours. But, no dew point.

1999年 9月17日 17時17分

オプトデバイス事業部 企画部

NO. 5431 P. 8

**SHARP CORPORATION**

ED-99170	August 30, 1999
MODEL No. GP2D120	PAGE 7/9

**REFERENCE****5. Incoming inspection****(1) Inspection lot**

Inspection shall be carried out per each delivery lot.

**(2) Inspection method**

A single sampling plan, normal inspection level II based on ISO 2859 shall be adopted.

Defect	Inspection items and test method	AQL(%)
Major defect	Electro-optical characteristics defect (In para. 3-3)	0.4
Minor defect	Defect on appearance and dimension * Split, chip, scratch, stain	1.0

\* Split  
Chip  
Scratch  
Stain

One which affects the characteristics  
of para. 3-3 shall be defect.



1999年 9月17日 17時17分

オプトデバイス事業部 企画部

NO. 5431 P. 9

SHARP CORPORATION

ED-99170	August 30, 1999
MODEL No. GP2D120	PAGE 8/9

**REFERENCE**

6-1 GP2D120 Example of Output distance characteristics

● White paper (Reflectance ratio 90%)
  \* Gray paper (Reflectance ratio 18%)

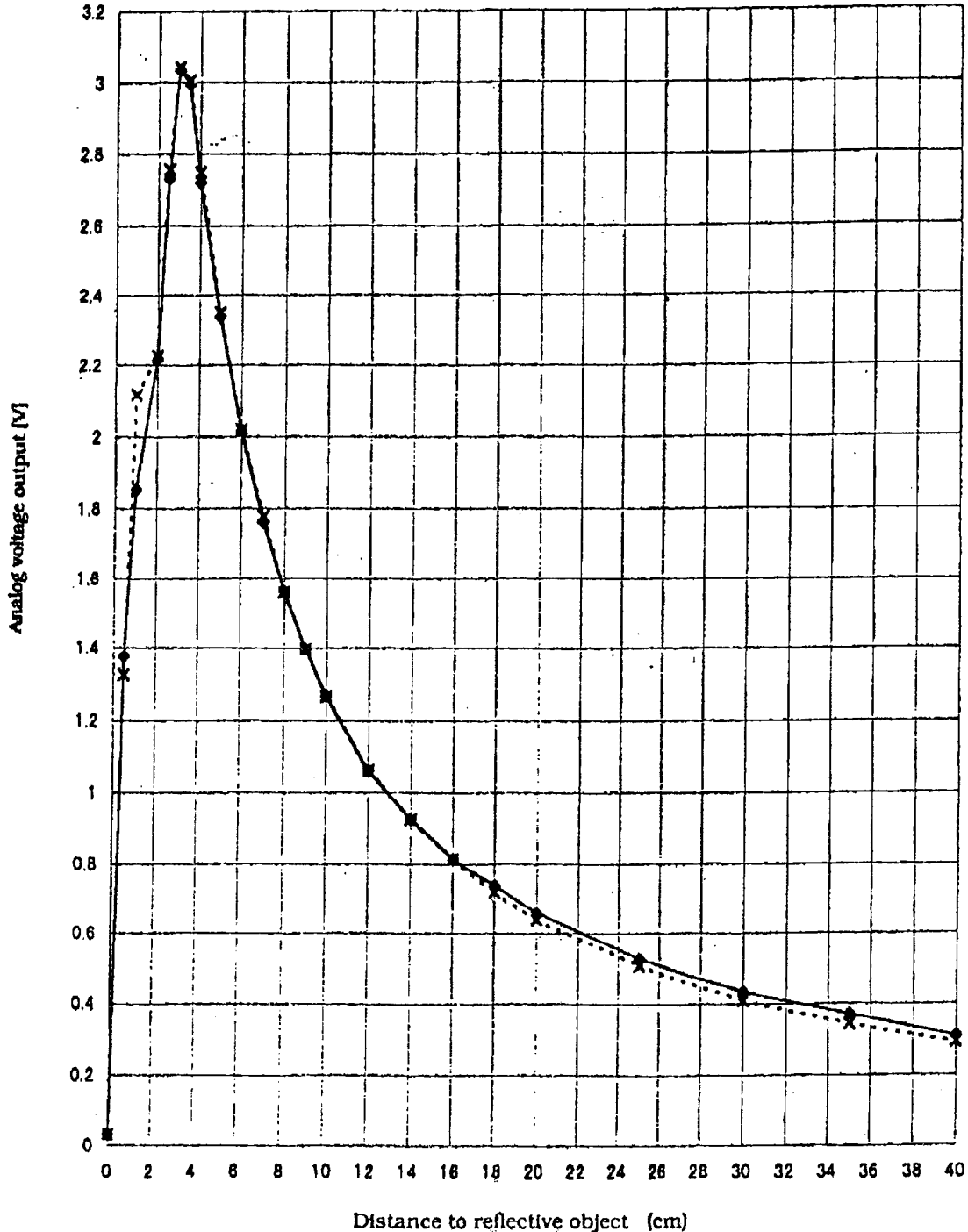

1999年 9月17日 17時17分

オプトデバイス事業部 企画部

NO. 5431 P. 10

SHARP CORPORATION

ED-99170

August 30, 1999

MODEL No.

GP2D120

PAGE

9/9

REFERENCE

6-2 GP2D120 Example of output characteristics with inverse number of distance

