

# Increasing the High Speed Torque of Bipolar Stepper Motors

National Semiconductor  
Application Note 828  
Steven Hunt  
May 1993



Increasing the High Speed Torque of Bipolar Stepper Motors

## INTRODUCTION

To successfully follow a velocity profile, a motor and drive combination must generate enough torque to: accelerate the load inertia at the desired rates, and drive the load torque at the desired speeds. While the size of a bipolar stepper motor generally dictates the low speed torque, the ability of the drive electronics to force current through the windings of the motor dictates the high speed torque. This application note shows that increasing the slew rates of the winding currents in a bipolar stepper motor pushes the motor to deliver more torque at high speeds. Simple voltage drives, L/R drives, and chopper drives are explained. L/R drives and chopper drives achieve slew rates higher than those achieved by simple voltage drives. Finally, an example chopper drive is presented.

## BACKGROUND

In standard full-step operation, quadrature (out of phase by 90°) bipolar currents (*Figure 1*) energize the windings of a bipolar stepper motor. One step occurs at each change of direction of either winding current, and the motor steps at four times the frequency of the currents. The ideal winding currents of *Figure 1* exhibit infinite slew rates.

Ideally, each phase contributes a sinusoidal torque;

$$T_1 = -i_1 T \sin(N\theta) \text{ and} \quad (1)$$

$$T_2 = i_2 T \cos(N\theta), \quad (2)$$

with the winding currents,  $i(t)$ , in amps and the torque constants,  $-T \sin(N\theta)$  and  $T \cos(N\theta)$ , in newton-centimeters per amp.  $\theta$  represents the angular displacement of the rotor

relative to a stable detent (zero torque) position.  $N$  represents the number of motor poles; that is, the number of electrical cycles per mechanical cycle or revolution.  $N\theta$ , therefore, represents the electrical equivalent of the mechanical rotor position. The torque contributions add directly to yield a total torque of

$$T_t = T_1 + T_2 = T (i_2 \cos(N\theta) - i_1 \sin(N\theta)). \quad (3)$$

Integrating (3) over a full period of one of the torque constants and multiplying the result by the reciprocal of that period gives the average torque generated by the motor. Assuming ideal square wave winding currents and sinusoidal torque constants (*Figure 2*), the motor generates an average torque of

$$T_{avg} = \frac{1}{2\pi} \left[ \int_0^{2\pi} -i_1 T \sin(N\theta) dN\theta + \int_0^{2\pi} i_2 T \cos(N\theta) dN\theta \right] = \quad (4)$$

$$= \frac{2}{\pi} I_{rated} T \cos\phi. \quad (5)$$

In open loop applications,  $\phi$  adjusts automatically to match the average torque generated by the motor with that required to execute a motion task. When the winding currents and their respective torque constants are in phase ( $\phi$  is zero), the motor generates the maximum average torque or *pull-out torque*;

$$T_{pull-out} = T_{avg}(\max) = \frac{2}{\pi} I_{rated} T. \quad (6)$$

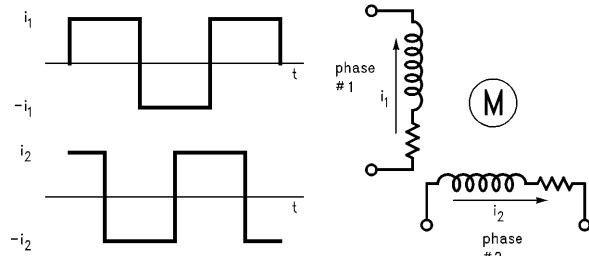

FIGURE 1. Ideal Quadrature Currents Drive the Windings of a Bipolar Stepper Motor

TL/H/11453-1

Square waves make good approximations for the winding currents at low speeds only, and (6), therefore, makes a good approximation of the pull-out torque at low speeds only. Real winding currents have an exponential shape dictated by the L/R-time constants of the windings, the voltage applied across the windings, and, to a lesser extent, the back emf generated by the motor as the rotor spins. For either winding,

$$i(t) = \left( I_0 - \frac{V_{CC} - V_{emf}}{R} \right) e^{-\frac{R}{L}t} + \frac{V_{CC} - V_{emf}}{R} \quad (7)$$

describes the winding current at a change in the direction of that current, where  $I_0$  is the initial winding current,  $V_{CC}$  is the voltage applied across the winding,  $V_{emf}$  is the back emf, and R and L are the winding resistance and inductance. At

low step rates, assuming  $V_{CC} = V_{rated} \gg V_{emf}$ , the current easily slews to the peak value of  $V_{rated}/R$  before a subsequent direction change (Figure 3a). At higher step rates, because the time between direction changes is shorter, the current cannot reach the peak value (Figure 3b).  $V_{rated}$  is the rated voltage of the windings.

Clearly from (4) and Figure 3, as the speed increases, decreases in the winding currents result in decreases in  $T_{pull-out}$ . The torque vs. speed characteristic of a typical bipolar stepper motor (Figure 4) reflects this phenomenon. Each pull-out torque curve bounds (on the right) a region of torque-speed combinations inside which the stepper motor runs and outside which the stepper motor stalls.

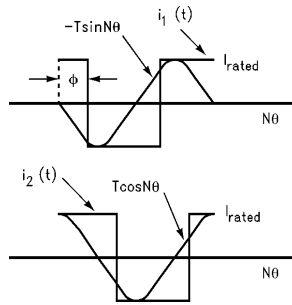

TL/H/11453-14

FIGURE 2. Ideal Square Wave Winding Currents and Sinusoidal Torque Constants for Average Torque Calculation

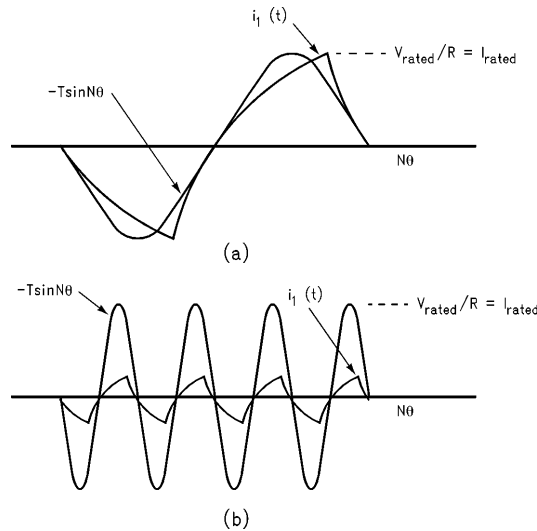

TL/H/11453-15

FIGURE 3. Real Winding Current and Sinusoidal Torque Constant vs Step Rate at Low Step Rates (a) and at High Step Rates (b)

It follows then, that the goal of increasing the high speed torque is achieved by increasing the winding currents at high speeds. This, in turn, is achieved by increasing the slew rates of the winding currents; for example, with the increased slew rates realized by raising  $V_{CC}$  well above  $V_{rated}$ , the winding current easily slews to the peak value of  $V_{rated}/R$  at both low and high step rates (Figure 5). Winding currents realized with  $V_{CC} = V_{rated}$  are represented with dashed lines, and, assuming a means for limiting at  $V_{rated}/R$ , winding currents realized with  $V_{CC} \gg V_{rated}$  are represented with solid lines.

Both decreasing the L/R-time constants of the windings and increasing the voltage applied across the windings increases the slew rates of the winding currents. L/R drives and chopper drives take these tactics to raise the slew rates of the winding currents well above those realized by simply applying the rated voltage to the windings. The torque vs. speed characteristic of a typical bipolar stepper motor (Figure 4 again) reflects the resulting high speed torque gains.

It is important to note, however, that applying  $V_{CC} \gg V_{rated}$  also results in excessive winding currents at low speeds. The winding currents must be held at or below the rated limit (usually  $V_{rated}/R$  per winding) to hold power dissipated inside the motor at or below the rated limit (usually  $2 \times V_{rated} \times I_{rated}$ ).

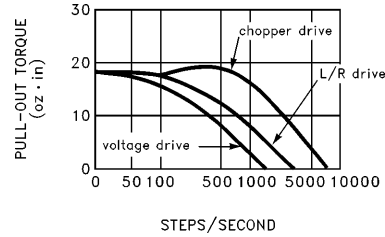

TL/H/11453-3

FIGURE 4. A Typical Torque vs Speed Characteristic of a Bipolar Stepper Motor

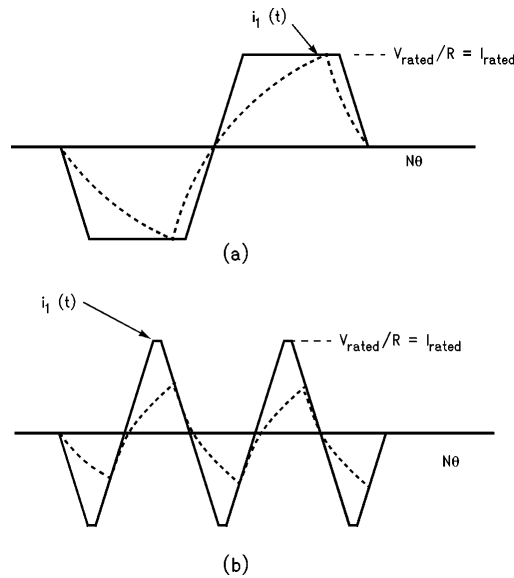

TL/H/11453-6

FIGURE 5. Real Winding Current vs Step Rate with  $V_{CC} \gg V_{rated}$  at Low Step Rates (a) and at High Step Rates (b)

### SIMPLE VOLTAGE DRIVES

Simple drives employ two H-bridge power amplifiers to drive bipolar currents through the phase windings (Figure 6). For either amplifier, closing switches S1 and S4 forces the rated voltage (less two switch drops) across the winding, and current flows from supply to ground via S1, the winding, and S4. After opening S1 and S4, closing S2 and S3 reverses the direction of current in the winding. This drive scheme is commonly referred to as simple voltage drive. Because only the winding resistances limit the winding currents,  $V_{CC}$  cannot exceed  $V_{rated}$ .

### L/R DRIVES

L/R drives employ two series power resistors to decrease the L/R-time constants of the windings; for example, a  $45\Omega$  power resistor in series with each of two  $15\Omega$  winding resistances divides the L/R-time constants by four and allows the rated supply voltage to be increased by a factor of four. Both the crispness of the response and the high speed torque are increased. While the rotor holds position or moves at low step rates, the series power resistors protect the motor by holding the winding currents to the rated limit.

Since both the L/R-time constants of the phase windings and the rated supply voltage were increased by a factor of four, the example drive would commonly be referred to as an L/4R drive.

The maximum operating supply voltage of the power amplifiers can limit the factor by which the supply voltage is increased above the rated voltage of the windings, but power losses in the series resistors more likely limit this factor. If, for example, 60V is applied across two 0.5A,  $15\Omega$  phase windings, two  $105\Omega$  series resistors are required to hold the winding currents to the 0.5A/phase limit. This is an L/8R drive. Power dissipated in the series resistors while the rotor holds position is  $105 \times 0.5 \times 0.5 \times 2 = 52.5W$ , while power dissipated in the entire drive is  $60 \times 0.5 \times 2 = 60W$ . The drive efficiency approaches 12.5%. After looking at these numbers, the drive designer may opt to cut losses by using the 30V power supply/45 $\Omega$  series resistor combination of an L/4R drive. Unfortunately, while the rotor holds position, total power dissipated in the series resistors remains high at 22.5W and drive efficiency remains low at 25%.

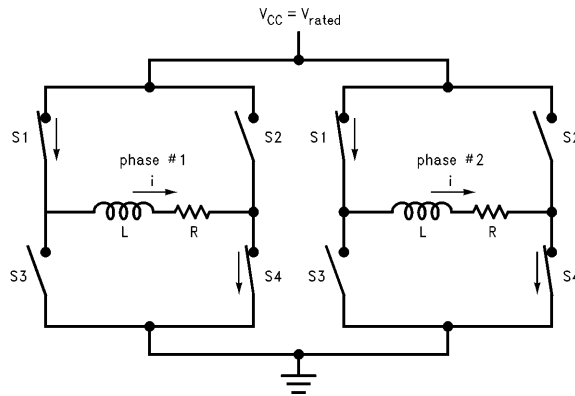

FIGURE 6. Simple Voltage Drive of a Bipolar Stepper Motor

TL/H/11453-2

### CHOPPER DRIVES

Chopper drives increase the slew rates of the winding currents by applying  $V_{CC} \gg V_{rated}$ . Feedback-driven switching of the H-bridges holds the winding currents to the rated limit. Figure 7 shows the chopping states of a single H-bridge of a chopper drive. A low value resistor in the ground lead of the H-Bridge converts the winding current into a proportional feedback voltage, and the feedback voltage is compared to a reference voltage (not shown). While the feedback voltage is less than the reference voltage, switches S1 and S4 apply the full supply voltage across the winding (Figure 7a), and the winding current increases rapidly. When the feedback voltage is equal to the reference voltage; that is, when the winding current reaches the desired limit, S1 and S2 short the winding for a fixed period or off-time (Figure 7b). During the off-time, the winding current recirculates and decays slowly. At the end of the off-time,

S1 and S4 reapply the full supply voltage across the winding, and the winding current again increases. Repetition of this sequence results in a *current chopping action* that limits the peak winding current to a level determined by the reference voltage and the resistor in the ground lead of the amplifier (Figure 7c),  $limit = V_{reference}/R_S$ . Chopping of the current only occurs when the current reaches the desired limit (usually the rated current of the winding). When the winding current changes direction to step the motor, the general operation remains the same except S2 is held closed and S1 and S3 are switched to limit the winding current. Because the H-bridge shorts the winding for a fixed period, this type of chopper drive is commonly referred to as a *fixed off-time* drive. By eliminating the series resistors required by L/R drives, chopper drives increase dramatically the drive efficiency. Typical efficiencies of chopper drives range from 75% to 90%.

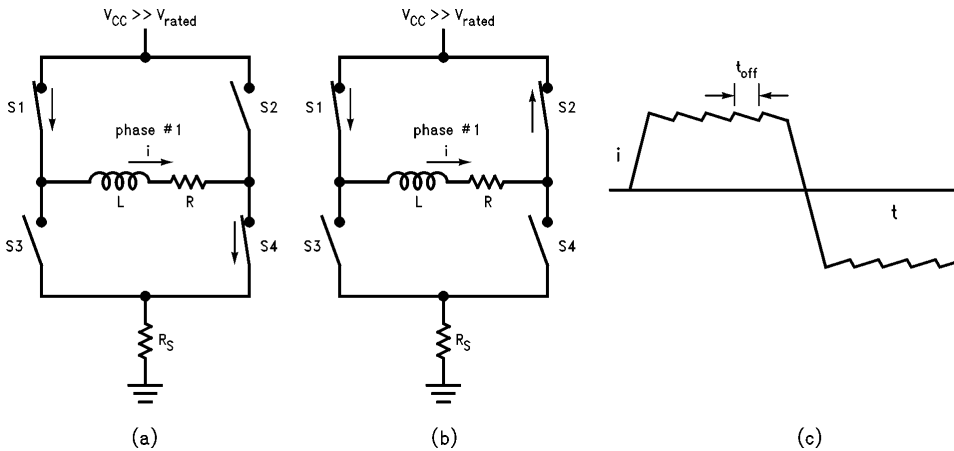

FIGURE 7. The Chopping States of a Single H-Bridge of a Chopper Drive: the Full  $V_{CC}$  is Applied Across the Winding (a), the Winding is Shorted (the Current Recirculates) (b), and the Chopped Winding Current (c)

TL/H/11453-7

### AN LMD18200-BASED CHOPPER DRIVE

The LMD18200 is a 3A, 55V H-bridge (Figure 8). It is built using a multi-technology process which combines bipolar and CMOS control (logic) and protection circuitry with DMOS power switches on the same monolithic structure. The LMD18200 data sheet and AN-694 contain more information about the operation of the LMD18200.

Two LMD18200 H-bridges form the core of an example chopper drive (Figure 9). The PWM input (pin #5) of each LMD18200 accepts a logic signal that controls the state of that device. While the signal at PWM is logic-high, the H-bridge applies the full supply voltage across the winding, and while the signal at PWM is logic-low, the upper two switches of the H-bridge short the winding. The feedback voltage associated with either H-bridge is directly proportional to the current in the winding driven by that device. One half of an LM319 dual comparator compares the feedback voltage to the reference voltage. While the feedback voltage is less than the reference voltage, the signal at PWM is logic-high, the LMD18200 applies the full supply voltage across the winding, and the winding current increases. When the winding current increases to the point the feedback voltage and the reference voltage are equal, the LM319 triggers the LMC555-based one-shot. For the duration of the one-shot timing pulse, the signal at PWM is logic-low, the LMD18200 shorts the winding, and the winding current *recirculates* and decays. After the timing pulse, the signal, a PWM returns to logic-high, the LMD18200 reap-

plies the full supply voltage across the winding, and the winding current again increases. Repetition of this sequence results in a current chopping action (Figure 10) that limits the winding current to the 0.5A rating while allowing the 12V, 24Ω winding to be driven with 36V. **Note:** the RC components associated with the LMC555 set the one-shot timing pulse. To best illustrate the current chopping action, the one-shot timing pulse or off-time was set at approximately 100μs. Shorter off-times yield smoother winding currents.

The Dir input (pin #3) of each LMD18200 accepts a logic signal that controls the direction of the current in the winding driven by that device; in other words, changing the logic level of the signal at Dir commands the motor to take a step.

This chopper drive takes advantage of the current sense amplifier on board the LMD18200. The current sense amplifier sources a signal level current that is proportional to the total forward current conducted by the two upper switches of the LMD18200. This *sense* current has a typical value of 377 μA per Amp of load current. A standard 1/4W resistor connected between the output of the current sense amplifier (pin #8) and ground converts the sense current into a voltage that is proportional to the load current. This proportional voltage is useful as a feedback signal for control and/or overcurrent protection purposes. The 18 kΩ resistors (Figure 9) set the gain of the drive at approximately 0.15A per volt of reference voltage (simply the reciprocal of the product of 377 μA/A and 18 kΩ).

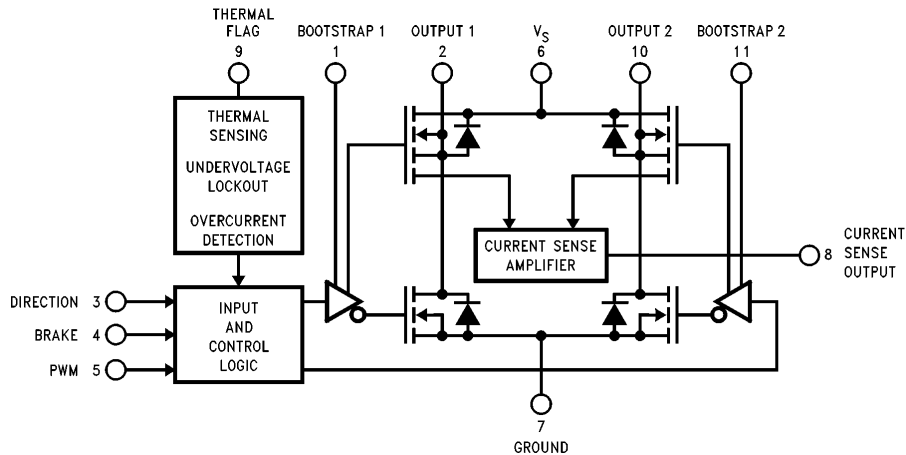

FIGURE 8. The LMD18200 3A, 55V Full H-Bridge

TL/H/11453-8

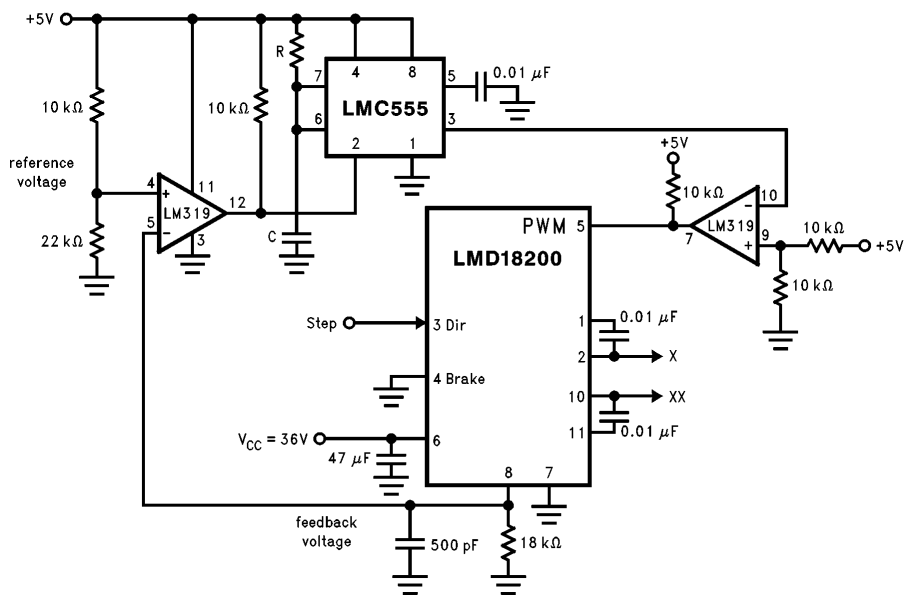
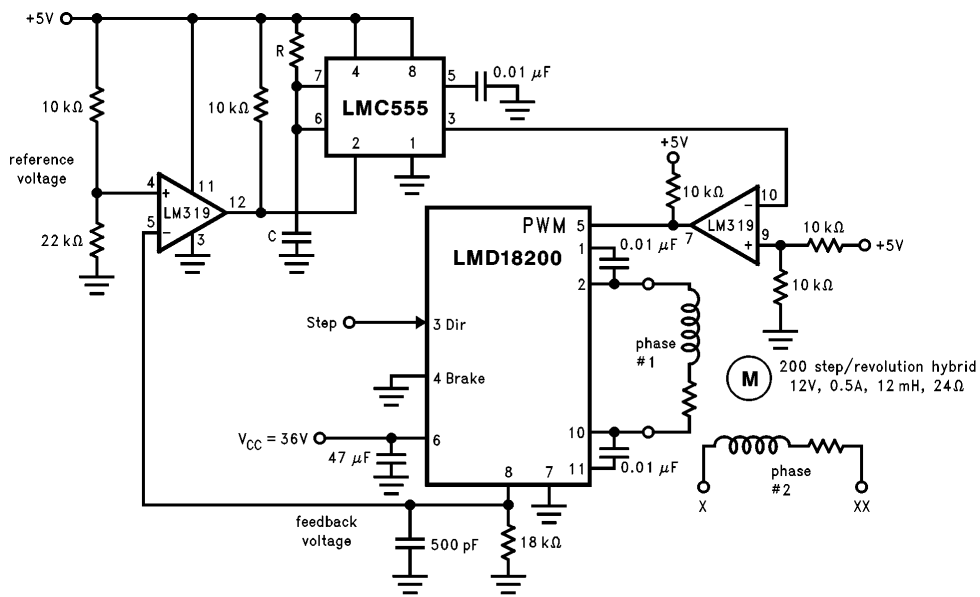

FIGURE 9. An LMD18200-Based Chopper Drive

TL/H/11453-9

During the current chopping action, the feedback voltage tracks the winding current (Figure 11). When the signal at Dir initiates a change in the direction of the winding current, the feedback voltage ceases tracking the winding current until the winding current passes through zero. This phenomenon occurs because the current sense amplifier only sources a current proportional to the total forward current conducted by the two upper switches of the LMD18200. During the period the feedback voltage does not track the winding current, the winding current actually flows from ground to supply as reverse current through a lower and an

upper switch of the H-bridge. Only after the winding current passes through zero does it once again become forward current in one of the upper switches (see AN-694). The feedback voltage is ground referenced; thus, it appears the same regardless of the direction of the winding current.

The same 200 step/revolution hybrid stepper (Figure 9) was used to generate Figures 10 through 13. Figure 12 shows the winding current for simple voltage drive with  $V_{CC} = V_{rated} = 12V$ . Figure 13 shows the winding current for L/4R drive with added series resistance of  $72\Omega$ /phase and  $V_{CC} = 4V_{rated} = 48V$ .

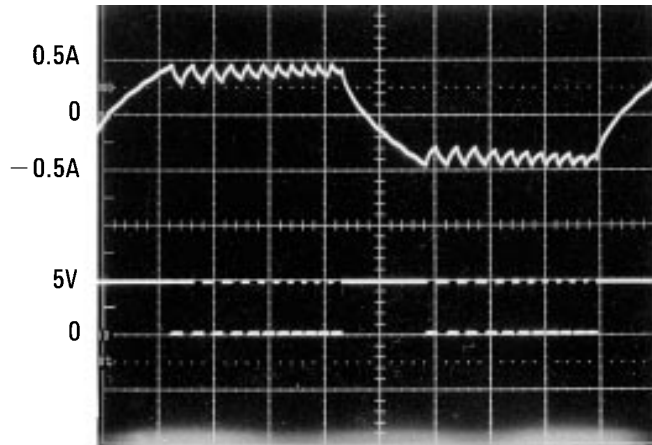

TL/H/11453-10

Top Trace: Winding Current at 0.5A/div  
 Bottom Trace: PWM Signal at 5V/div  
 Horizontal: 0.5 ms/div

**FIGURE 10. The Chopped Winding Current and the Logic Signal at PWM**

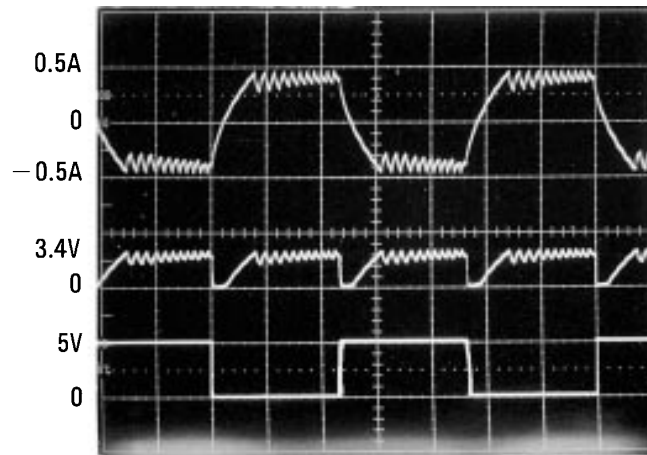

TL/H/11453-11

Top Trace: Winding Current at 0.5A/div  
 Middle Trace: Feedback Voltage at 5V/div  
 Bottom Trace: Step Logic Signal at 5V/div  
 Horizontal: 1 ms/div

**FIGURE 11. The Chopped Winding Current and Feedback Voltage at 860 Steps/Second**



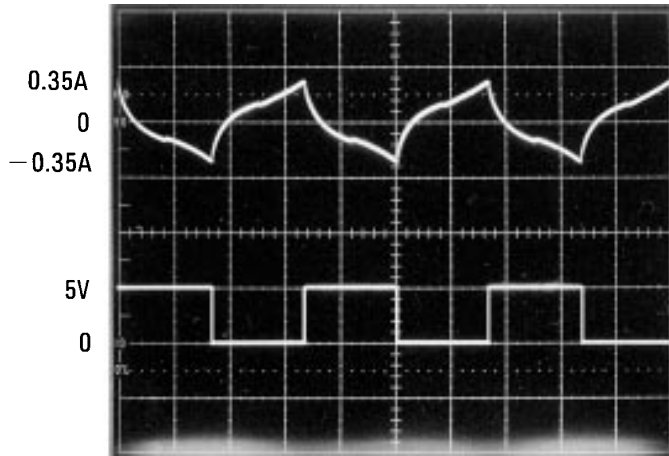

TL/H/11453-12

Top Trace: Winding Current at 0.5A/div  
 Bottom Trace: Step Logic Signal at 5V/div  
 Horizontal: 2 ms/div

**FIGURE 12. The Winding Current for Simple Voltage Drive at 600 Steps/Second**

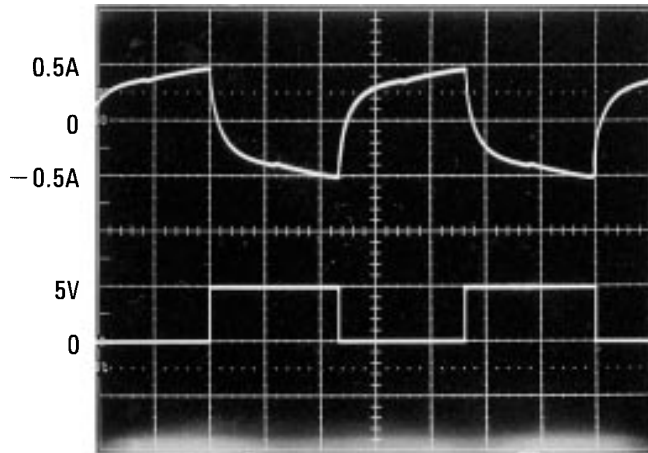

TL/H/11453-13

Top Trace: Winding Current at 0.5A/div  
 Bottom Trace: Step Logic Signal at 5V/div  
 Horizontal: 1 ms/div

**FIGURE 13. The Winding Current for L/4R Drive at 860 Steps/Second**

**LIFE SUPPORT POLICY**

NATIONAL'S PRODUCTS ARE NOT AUTHORIZED FOR USE AS CRITICAL COMPONENTS IN LIFE SUPPORT DEVICES OR SYSTEMS WITHOUT THE EXPRESS WRITTEN APPROVAL OF THE PRESIDENT OF NATIONAL SEMICONDUCTOR CORPORATION. As used herein:

1. Life support devices or systems are devices or systems which, (a) are intended for surgical implant into the body, or (b) support or sustain life, and whose failure to perform, when properly used in accordance with instructions for use provided in the labeling, can be reasonably expected to result in a significant injury to the user.
2. A critical component is any component of a life support device or system whose failure to perform can be reasonably expected to cause the failure of the life support device or system, or to affect its safety or effectiveness.



**National Semiconductor Corporation**  
 2900 Semiconductor Drive  
 P.O. Box 58090  
 Santa Clara, CA 95052-8090  
 Tel: 1(800) 272-9959  
 TWX: (910) 339-9240

**National Semiconductor GmbH**  
 Livny-Gargan-Str. 10  
 D-82256 Fürstfeldbruck  
 Germany  
 Tel: (81-41) 35-0  
 Telex: 527849  
 Fax: (81-41) 35-1

**National Semiconductor Japan Ltd.**  
 Sumitomo Chemical  
 Engineering Center  
 Bldg. 7F  
 1-7-1, Nakase, Mihama-Ku  
 Chiba-City,  
 Ciba Prefecture 261  
 Tel: (043) 299-2300  
 Fax: (043) 299-2500

**National Semiconductor Hong Kong Ltd.**  
 13th Floor, Straight Block,  
 Ocean Centre, 5 Canton Rd.  
 Tsimshatsui, Kowloon  
 Hong Kong  
 Tel: (852) 2737-1600  
 Fax: (852) 2736-9960

**National Semicondutores Do Brazil Ltda.**  
 Rue Deputado Lacorda Franco  
 120-3A  
 Sao Paulo-SP  
 Brazil 05418-000  
 Tel: (55-11) 212-5066  
 Telex: 391-1131931 NSBR BR  
 Fax: (55-11) 212-1181

**National Semiconductor (Australia) Pty, Ltd.**  
 Building 16  
 Business Park Drive  
 Monash Business Park  
 Nottingham, Melbourne  
 Victoria 3168 Australia  
 Tel: (3) 558-9999  
 Fax: (3) 558-9998

National does not assume any responsibility for use of any circuitry described, no circuit patent licenses are implied and National reserves the right at any time without notice to change said circuitry and specifications.